

User Manual

BGM500 Series Barrier Gate

Date: February 2023

Doc Version: 1.0

English

Thank you for choosing our product. Please read the instructions carefully before operation. Follow these instructions to ensure that the product is functioning properly. The images shown in this manual are for illustrative purposes only.



For further details, please visit our Company's website
www.zkteco.com.

Copyright © 2022 ZKTECO CO., LTD. All rights reserved.

Without the prior written consent of ZKTeco, no portion of this manual can be copied or forwarded in any way or form. All parts of this manual belong to ZKTeco and its subsidiaries (hereinafter the "Company" or "ZKTeco").

Trademark

ZKTeco is a registered trademark of ZKTeco. Other trademarks involved in this manual are owned by their respective owners.

Disclaimer

This manual contains information on the operation and maintenance of the ZKTeco equipment. The copyright in all the documents, drawings, etc. in relation to the ZKTeco supplied equipment vests in and is the property of ZKTeco. The contents hereof should not be used or shared by the receiver with any third party without the express written permission of ZKTeco.

The contents of this manual must be read as a whole before starting the operation and maintenance of the supplied equipment. If any of the content(s) of the manual seems unclear or incomplete, please contact ZKTeco before starting the operation and maintenance of the said equipment.

It is an essential pre-requisite for the satisfactory operation and maintenance that the operating and maintenance personnel are fully familiar with the design and that the said personnel have received thorough training in operating and maintaining the machine/unit/equipment. It is further essential for the safe operation of the machine/unit/equipment that personnel has read, understood and followed the safety instructions contained in the manual.

In case of any conflict between terms and conditions of this manual and the contract specifications, drawings, instruction sheets or any other contract-related documents, the contract conditions/documents shall prevail. The contract specific conditions/documents shall apply in priority.

ZKTeco offers no warranty, guarantee or representation regarding the completeness of any information contained in this manual or any of the amendments made thereto. ZKTeco does not extend the warranty of any kind, including, without limitation, any warranty of design, merchantability or fitness for a particular purpose.

ZKTeco does not assume responsibility for any errors or omissions in the information or documents which are referenced by or linked to this manual. The entire risk as to the results and performance obtained from using the information is assumed by the user.

ZKTeco in no event shall be liable to the user or any third party for any incidental, consequential, indirect, special, or exemplary damages, including, without limitation, loss of business, loss of profits, business interruption, loss of business information or any pecuniary loss, arising out of, in connection with, or relating to the use of the information contained in or referenced by this manual, even if ZKTeco has been advised of the possibility of such damages.

This manual and the information contained therein may include technical, other inaccuracies or typographical errors. ZKTeco periodically changes the information herein which will be incorporated into new additions/amendments to the manual. ZKTeco reserves the right to add, delete, amend or modify the information contained in the manual from time to time in the form of circulars, letters, notes, etc. for better operation and safety of the machine/unit/equipment. The said additions or amendments are meant for improvement /better operations of the machine/unit/equipment and such amendments shall not give any right to claim any compensation or damages under any circumstances.

ZKTeco shall in no way be responsible (i) in case the machine/unit/equipment malfunctions due to any non-compliance of the instructions contained in this manual (ii) in case of operation of the machine/unit/equipment beyond the rate limits (iii) in case of operation of the machine and equipment in conditions different from the prescribed conditions of the manual.

The product will be updated from time to time without prior notice. The latest operation procedures and relevant documents are available on <http://www.zkteco.com>.

If there is any issue related to the product, please contact us.

ZKTeco Headquarters

Address ZKTeco Industrial Park, No. 32, Industrial Road,
Tangxia Town, Dongguan, China.

Phone +86 769 - 82109991

Fax +86 755 - 89602394

For business-related queries, please write to us at sales@zkteco.com.

To know more about our global branches, visit www.zkteco.com.

About the Company

ZKTeco is one of the world's largest manufacturer of RFID and Biometric (Fingerprint, Facial, Finger-vein) readers. Product offerings include Access Control readers and panels, Near & Far-range Facial Recognition Cameras, Elevator/floor access controllers, Turnstiles, License Plate Recognition (LPR) gate controllers and Consumer products including battery-operated fingerprint and face-reader Door Locks. Our security solutions are multi-lingual and localized in over 18 different languages. At the ZKTeco state-of-the-art 700,000 square foot ISO9001-certified manufacturing facility, we control manufacturing, product design, component assembly, and logistics/shipping, all under one roof.

The founders of ZKTeco have been determined for independent research and development of biometric verification procedures and the productization of biometric verification SDK, which was initially widely applied in PC security and identity authentication fields. With the continuous enhancement of the development and plenty of market applications, the team has gradually constructed an identity authentication ecosystem and smart security ecosystem, which are based on biometric verification techniques. With years of experience in the industrialization of biometric verifications, ZKTeco was officially established in 2007 and now has been one of the globally leading enterprises in the biometric verification industry owning various patents and being selected as the National High-tech Enterprise for 6 consecutive years. Its products are protected by intellectual property rights.

About the Manual

This manual introduces the operations of **BGM500 Series Barrier Gate**.

All figures displayed are for illustration purposes only. Figures in this manual may not be exactly consistent with the actual products.

Table of Contents

1	OVERVIEW	6
2	FEATURES AND FUNCTIONALITIES	6
3	APPEARANCE AND DIMENSIONS	6
4	SPECIFICATIONS	7
5	INSTALLATION PROCEDURE	7
5.1	INSTALLATION PRECAUTIONS	7
5.2	CABLE EMBEDDING	8
5.3	BOOM INSTALLATION	8
5.3.1	BOOM INSTALLATION PROCEDURE	8
5.3.2	INSTALLATION OF THE FOLDING BOOM.....	9
5.3.3	INSTALLATION OF THE FENCE BOOM ARM	10
6	DEFINITION OF LEFT AND RIGHT DIRECTIONS	11
7	MAINBOARD WIRING INSTRUCTIONS	11
7.1	CONNECTION WITH LPR CAMERA	12
7.2	CONNECTION WITH UHF CONTROLLER	12
7.3	CONNECTION WITH LOOP DETECTOR	13
7.4	CONNECTION WITH VR10 RADAR SENSOR.....	14
7.5	CONNECTION WITH INFRARED/PHOTOCELL DETECTOR.....	15
8	FUNCTIONAL PARAMETER SETTINGS	16
8.1	MAINBOARD PARAMETER SETTINGS	16
8.1.1	OPERATING PROCEDURE	17
8.2	PARAMETER SETTINGS DESCRIPTION	17
8.3	ERROR CODE.....	21
8.4	REMOTE CONTROL PAIRING AND UNPAIRING	22
8.4.1	PAIRING.....	22
8.4.2	UNPAIRING.....	22
8.5	SET DELAY FOR AUTOMATIC CLOSING AFTER OPENING THE BOOM ARM.....	22
9	BOOM ARM ADJUSTMENTS	23
9.1	DIMENSIONS	23
9.2	HORIZONTAL AND VERTICAL ANGLE ADJUSTMENT OF BOOM ARM (MECHANICAL ADJUSTMENT)	23
9.3	DIRECTION INTERCHANGE OF THE BOOM ARM	25

9.4	SPRING ADJUSTMENT	26
10	PRODUCT PACKING LIST	26
11	TROUBLESHOOTING	27

1 Overview

BGM500 series parking barrier adopts streamlined appearance style design, built-in LED indicator; Integrated brushless DC motor gear box all-in-one transmission mechanism and intelligent ZKBarrier mainboard, MCBF can reach 3 million maintenance free.

Apply to schools, communities, factories, office buildings and so on.

2 Features and Functionalities

- Highly energy-efficient because of the DC brushless motor.
- Digital control mainboard with diverse configuration possibilities.
- The barrier arm will rebound when an obstacle detected.
- Reversible boom direction.
- Chassis with LED indicator.
- Manual rise and fall in case of absence of power.
- Support the boom breakaway design.
- Various barrier arm.

3 Appearance and Dimensions

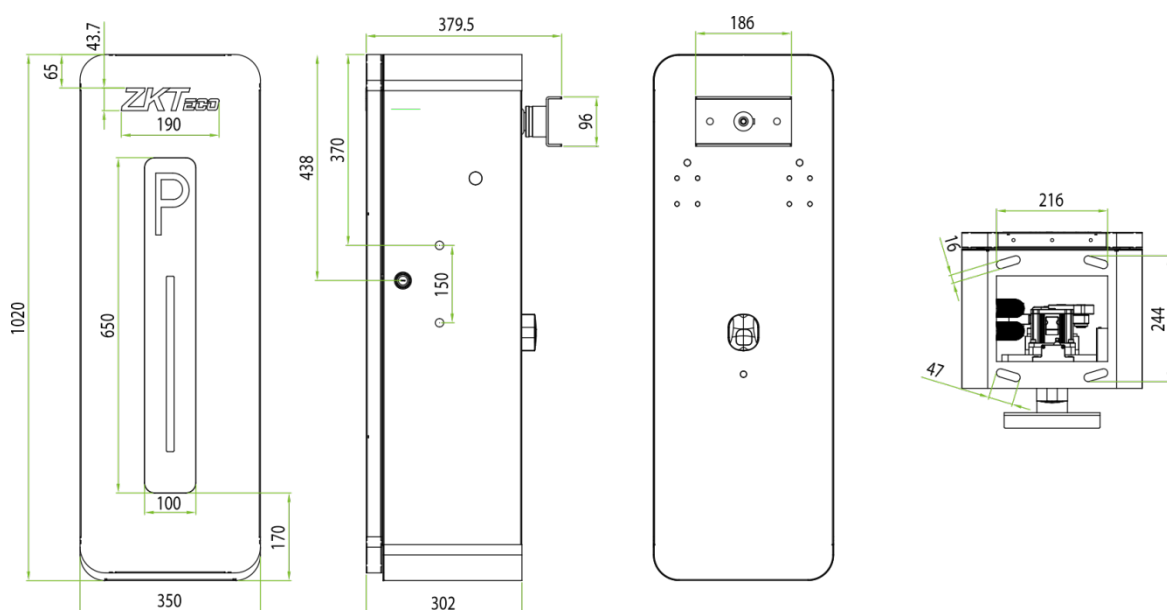

4 Specifications

Model	BGM530 L/R	BGM545 L/R	BGM560 L/R	BGM545 L/R-LED	BGM545 L/R-90	BGM545 L/R-F
Operating Speed	1.5s	2.5s	5s	2.5s	3s	2.5s
Boom Length	3m	4.5m	6m	4.5m	4.5m	4.5m
Boom Type	Straight boom	Telescopic boom		Straight boom with LED	Folding boom	Fence boom
Motor Type	DC 24V brushless motor					
Output Power	160W					
Output Current	10A					
Operating Voltages	DC 24V					
Power Supply	AC 220V/110V, 50Hz to 60Hz					
MCBF	3 million times					
Remote Control Distance	≥30m					
Operating Temperature	-30°C to 75°C					
Protection Level	IP54					
Chassis Dimensions (mm)	350*302*1020 (mm)					
Net Weight (excluding the barrier arm)	43 kg					

5 Installation Procedure

5.1 Installation Precautions

1. Install the parking barrier on a level ground. If the ground is not firm and level, a cement base is needed before the installation.
2. The length of the boom can be cut but cannot be increased. To establish new balance after cutting the boom length, the spring balance must be reset. The bottom of the spring has two plastic nuts for adjusting the new balance.
3. When the power is on, do not make any changes to the wire connections inside.
4. The GND should be connected to the cabinet for secure protection.

5.2 Cable Embedding

1. Prepare for a total of $\phi 25$ protective sleeve and cable in advance.
2. Connect the route cables through the protective sleeves.
3. Use a tool to open a cable tray on the ground.

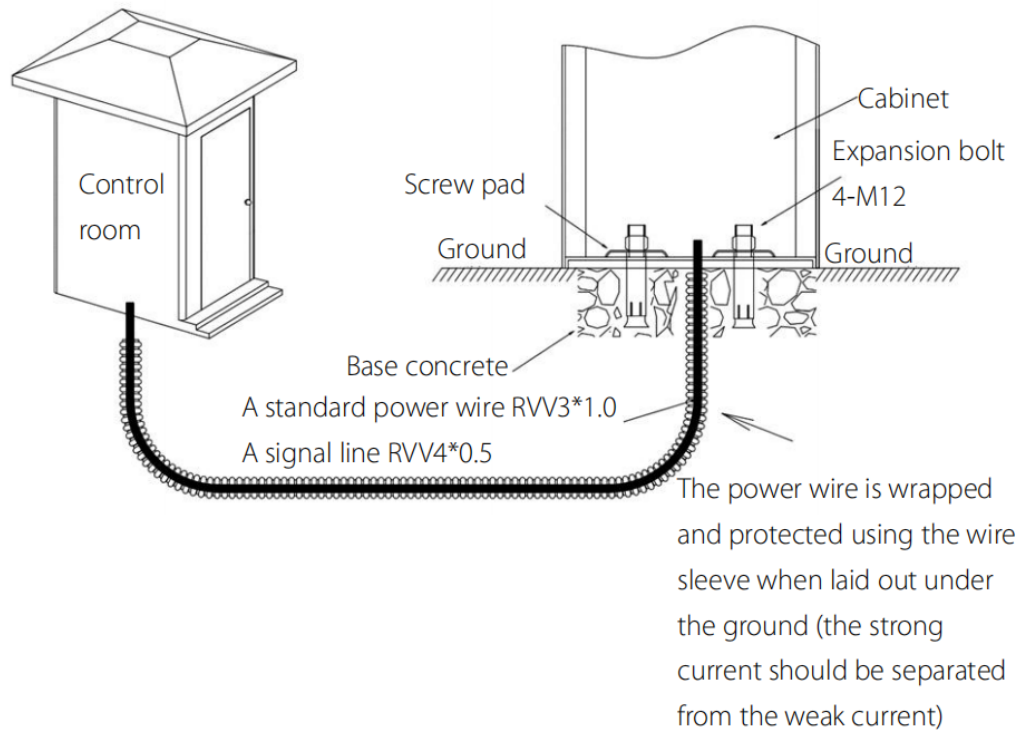

5.3 Boom Installation

5.3.1 Boom Installation Procedure

1. Pull the vice boom out from the main boom and install them with the two screws, as shown in Figure 1.
2. Install the boom to the chassis, as shown in Figure 2.

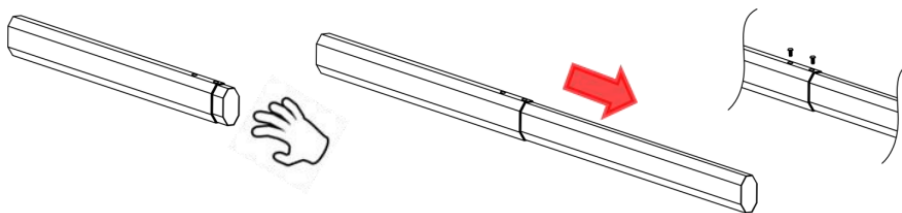

Figure 1 Connect the main boom with the vice together by 2 screws

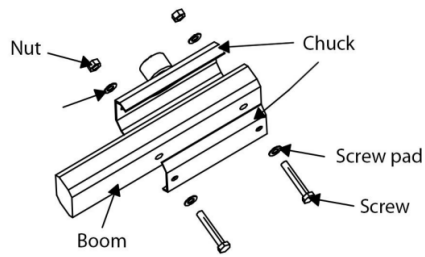
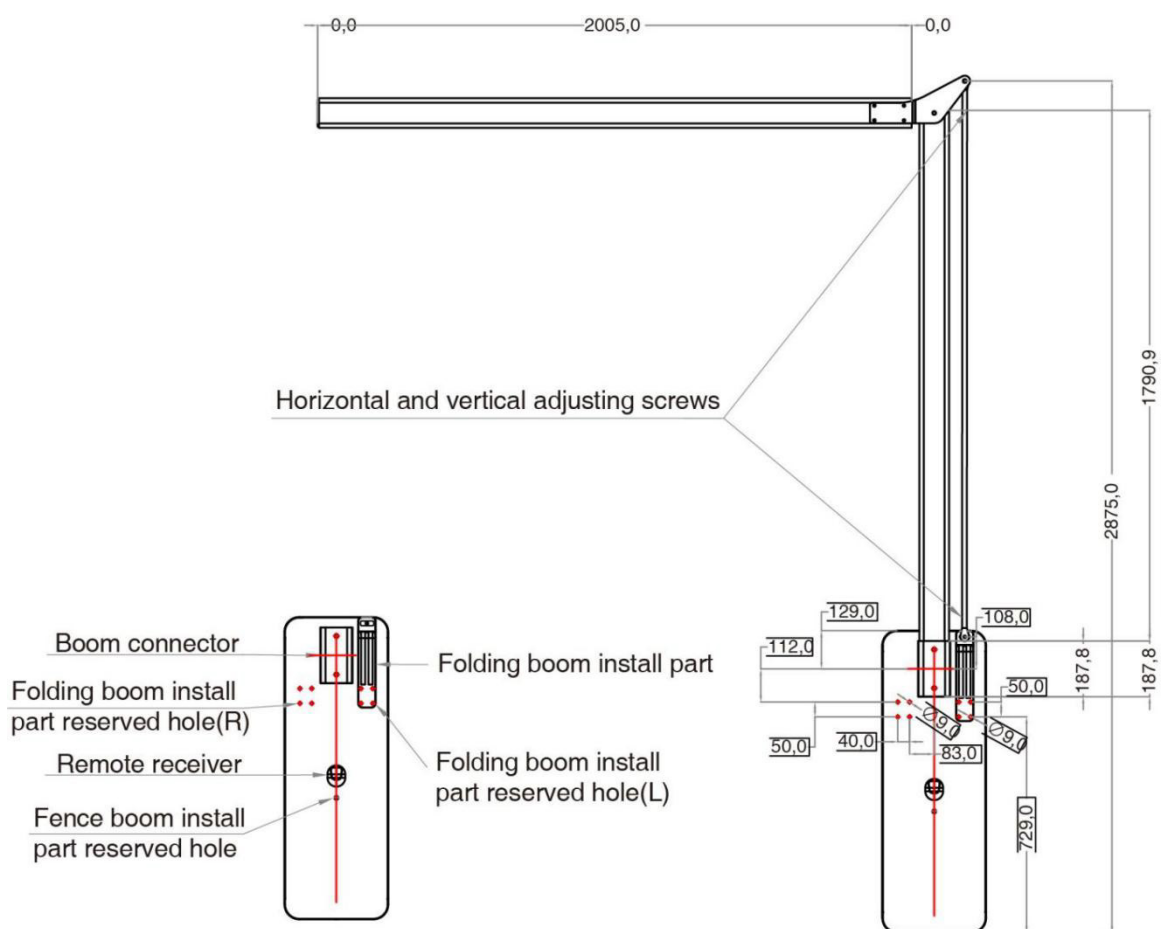

Figure 2 Installing the Boom to the Chassis

5.3.2 Installation of the Folding Boom



1. Install the folding boom assembly element after disconnecting the machine's power.
2. Fix the folding boom.
3. Adjust the vertical and horizontal position of the boom arm.
4. Start the power supply and observe the running state of the machine. If the boom arm open shaking, it is then necessary to loosen the spring and slow down the speed

appropriately. It is also necessary to tighten the spring and slow down the speed accordingly if the boom arm closes shaking.

Note:

Default total height: $H \leq 2.8\text{m}$, Default total length: $L \leq 4.5\text{m}$ (Support customization, specify total height and total length in the order remarks)

5.3.3 Installation of the Fence Boom Arm

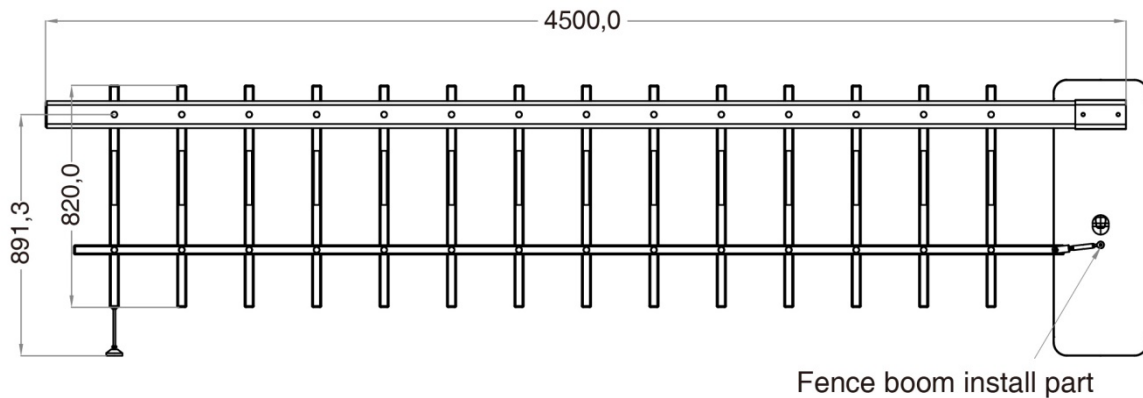

1. Install the fence boom install part after disconnecting the machine's power.
2. Fix the fence boom.
3. Adjust the vertical and horizontal position of the boom arm.
4. Start the power supply and observe the running state of the machine. If the boom arm open shaking, it is then necessary to loosen the spring and slow down the speed appropriately. It is also necessary to tighten the spring and slow down the speed accordingly if the boom arm closes shaking.

Notes:

- 1) Before the machine is energized to run the test, please make sure to install the barrier boom of the corresponding length for the test. If the barrier boom is not installed, please adjust, and remove the spring under the guidance of a professional person.
- 2) If the length of the barrier boom is cut and adjusted, the tightness of the spring and the position of the hanging hole must to adjusted accordingly in order to avoid the abnormal condition of the machine that cannot drop the boom.

6 Definition of Left and Right Directions



**L: The chassis on the left,
the boom on the right.**

**R: The chassis on the right,
the boom on the left.**

7 Mainboard Wiring Instructions

1. Please disconnect the power supply before wiring.
2. Please note that to switch the input voltage to 110V, you must set the DIP switch on the power supply to the following:

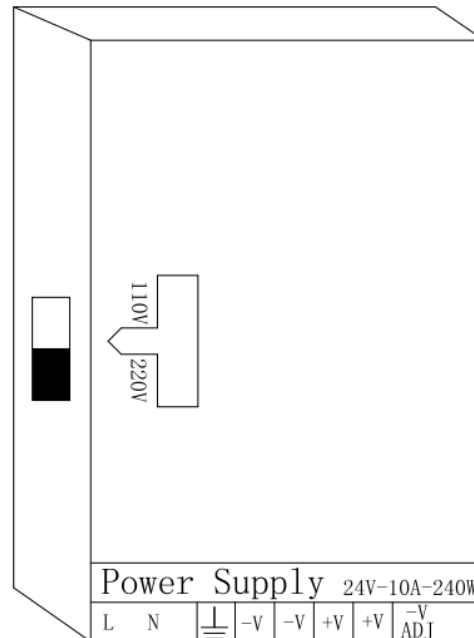

3. Make sure the terminals are securely fastened and the wiring is secure.
4. The wiring diagram of the control panel is explained as follows:

BGM500 Wiring Diagram of Mainboard

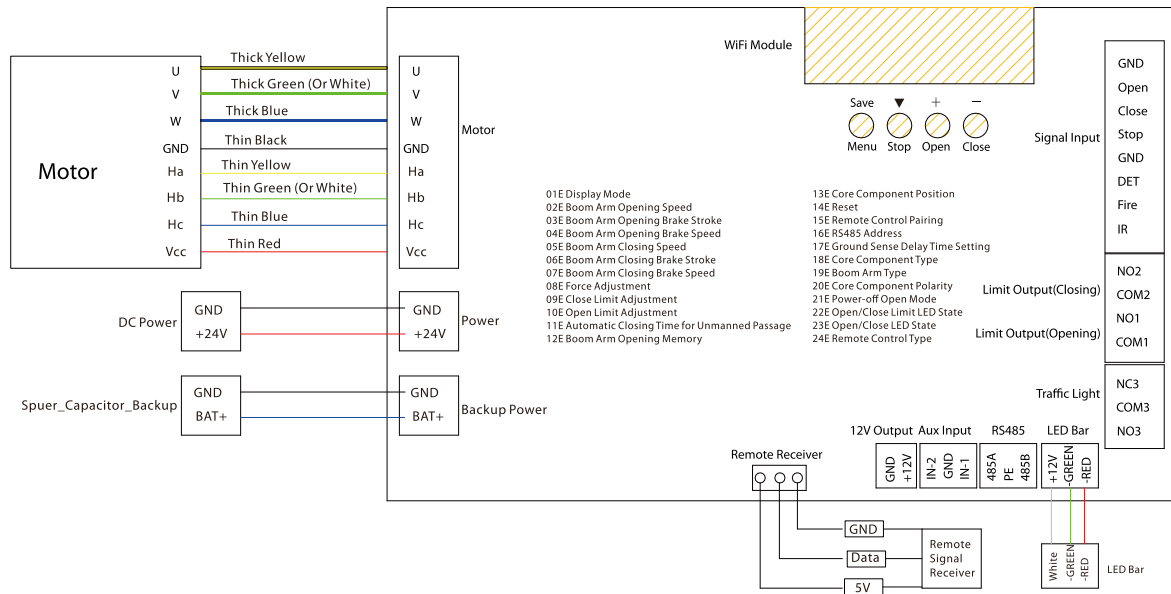

7.1 Connection with LPR Camera

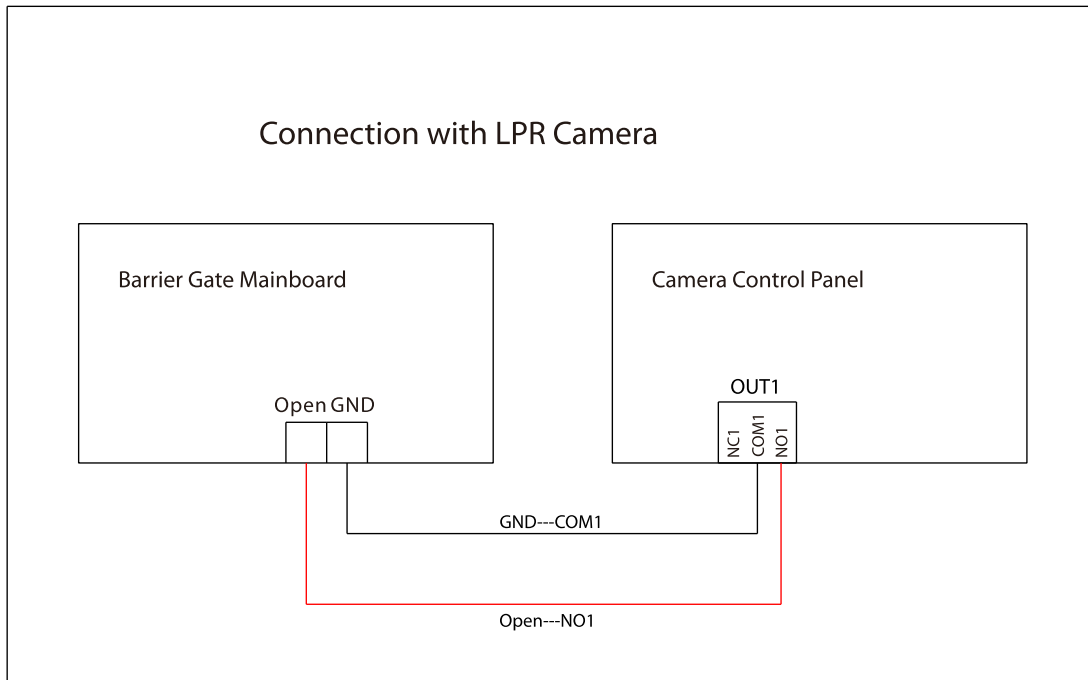

7.2 Connection with UHF Controller

(Note: The reader 1 and 2 of Inbio260 Controller corresponds to LOCK1, Reader 3 and 4 corresponds to LOCK2)

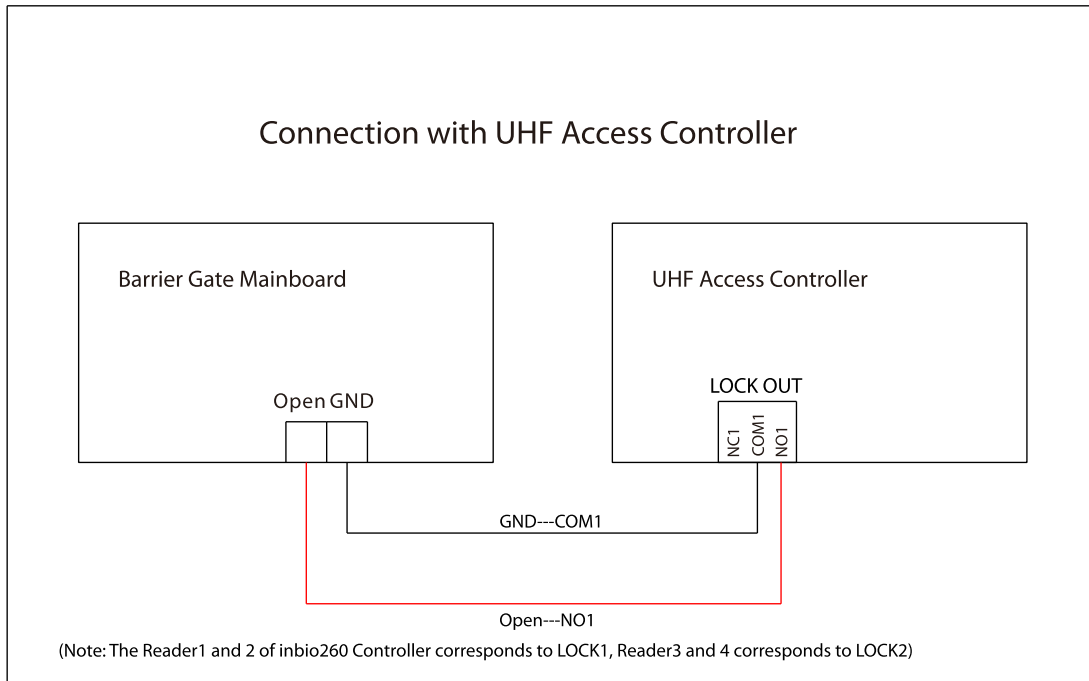

7.3 Connection with Loop Detector

Anti-smash and Auto-close function:

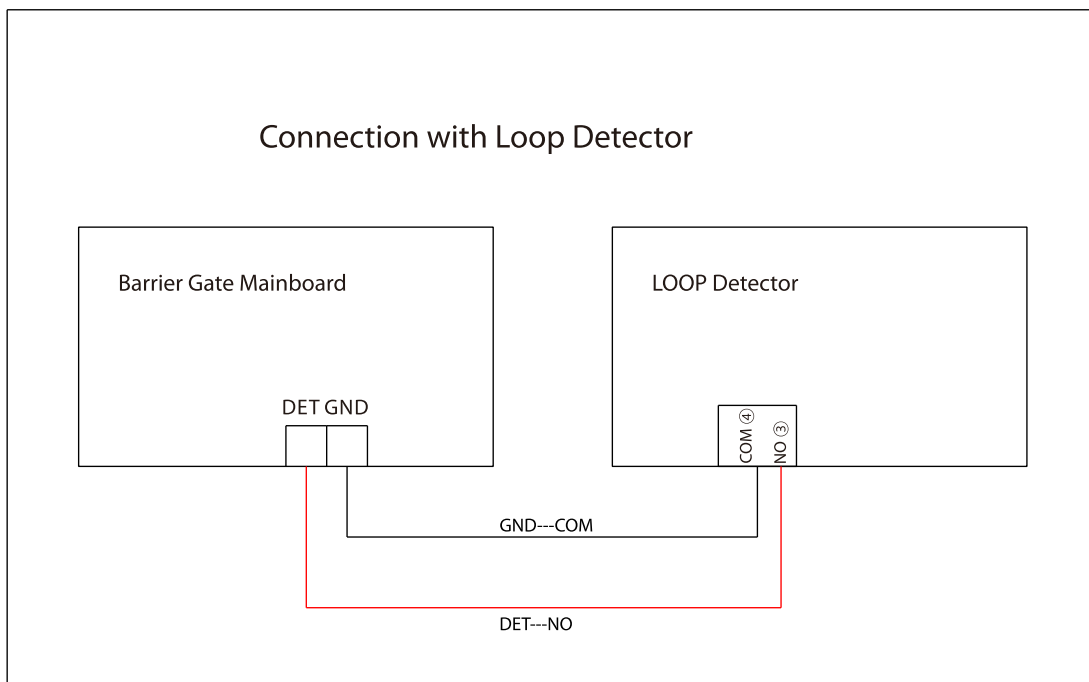

Coil Circumference	Coil Number
3m	Based on requirements, ensure that the inductance is between 100 μ H to 200 μ H
3m to 6m	5 to 6 turns
6m to 10m	4 to 5 turns
10m to 25m	3 turns
25m	2 turns

7.4 Connection with VR10 Radar Sensor

Anti-smash and Auto-close function

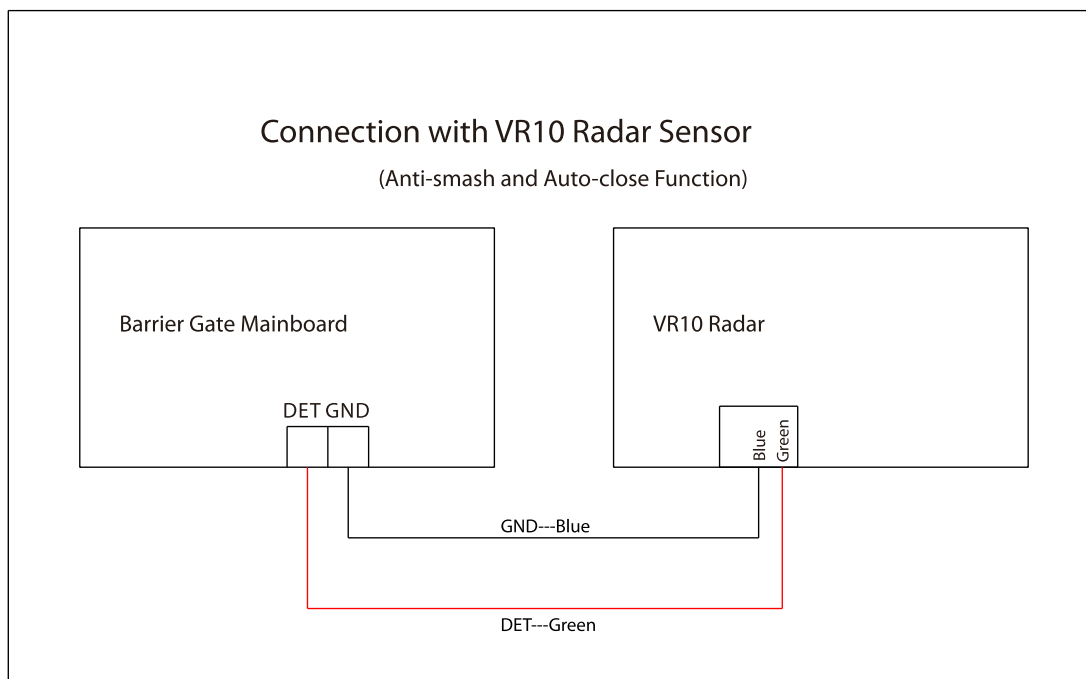

7.5 Connection with Infrared/Photocell Detector

Anti-smash function

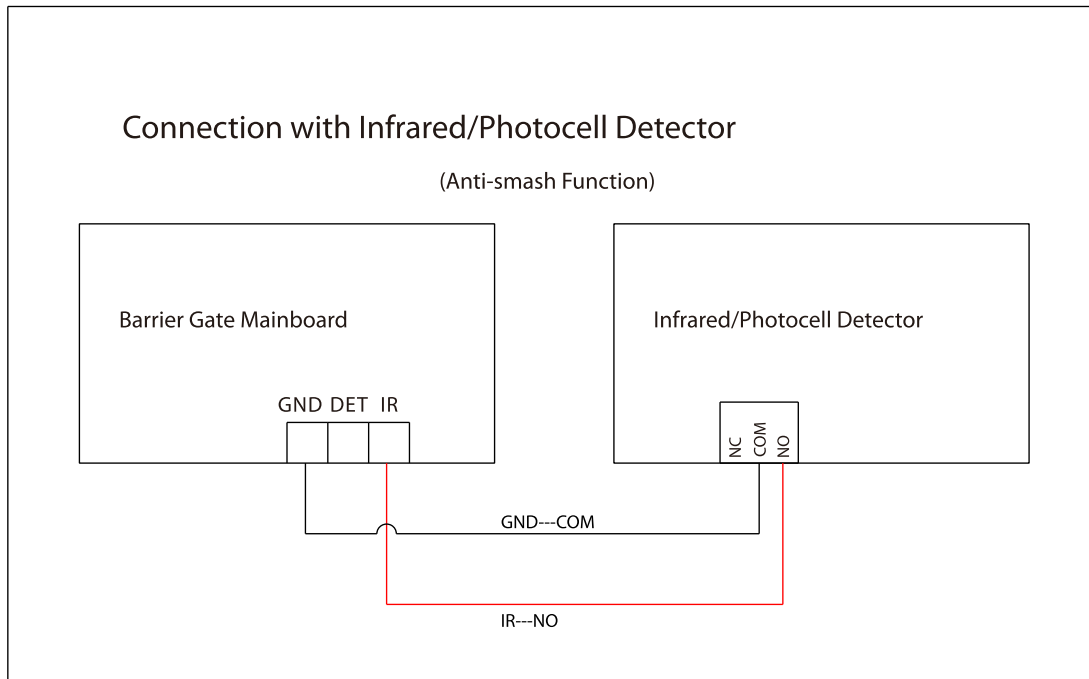

Anti-smash and Auto-close function

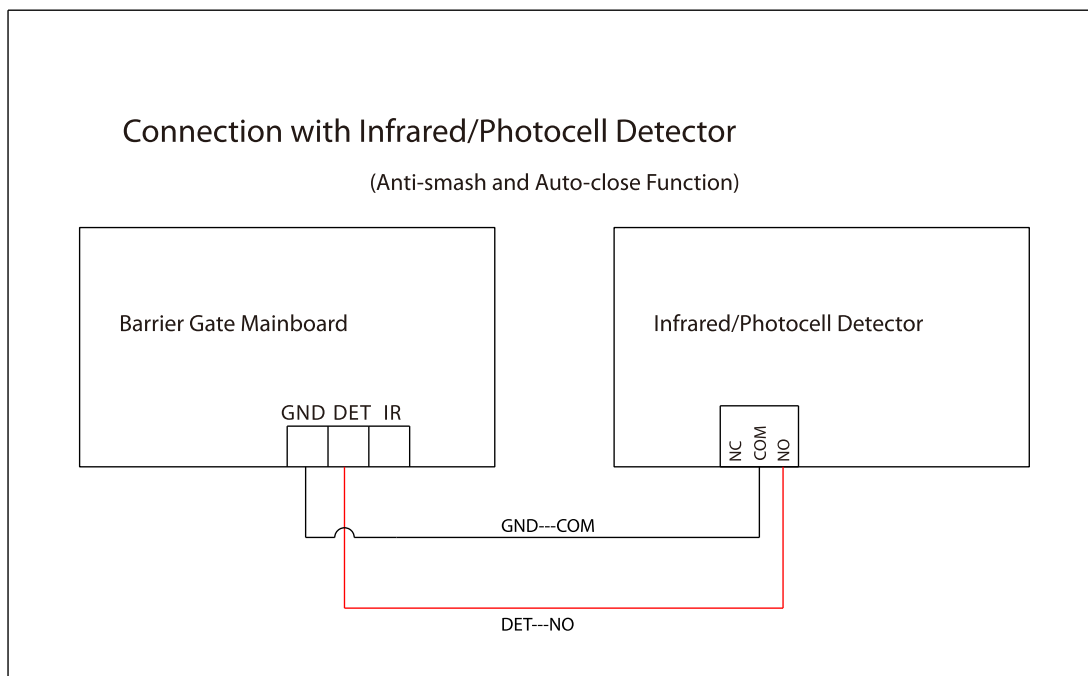

◆ Mounting height

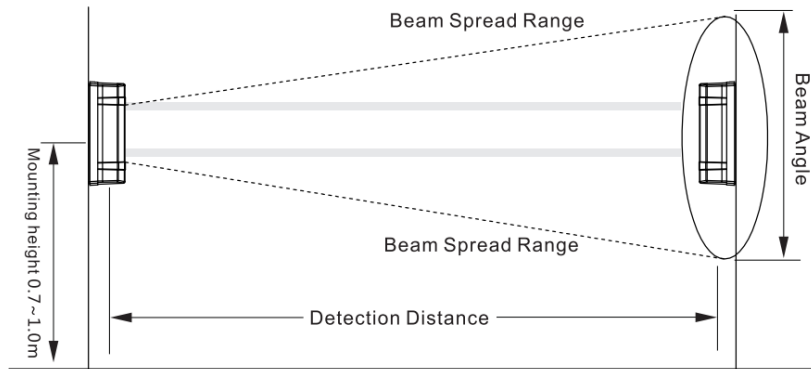

◆ Adjusting angle

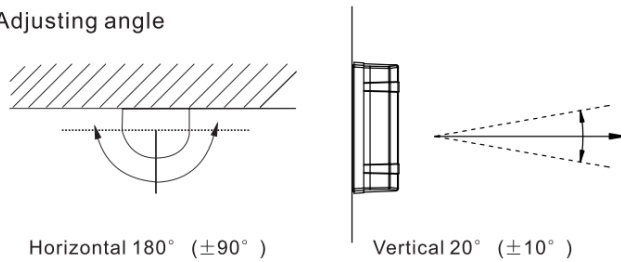

Notice: For best testing results, please avoid testing in 45°

8 Functional Parameter Settings

After the initial installation, and first power-on, you must use the "Open" and "Close" buttons on the mainboard to complete the self-check process and learn the description of the menu.

8.1 Mainboard Parameter Settings

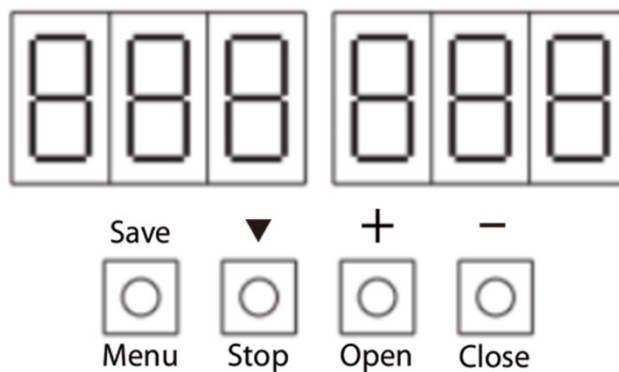

Menu/Save: Menu options/Confirm and Save

Stop/▼: Stop the boom arm /button to switch the menu item and the value item

Open/+: Increase parameter/value

Close/-: Decrease parameter/value

8.1.1 Operating Procedure

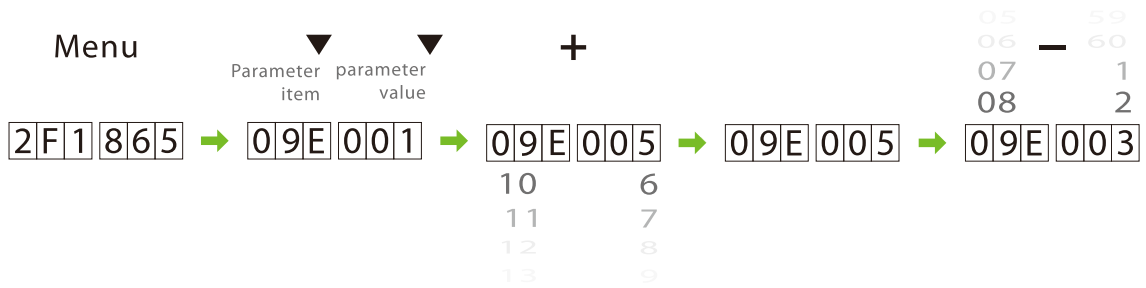
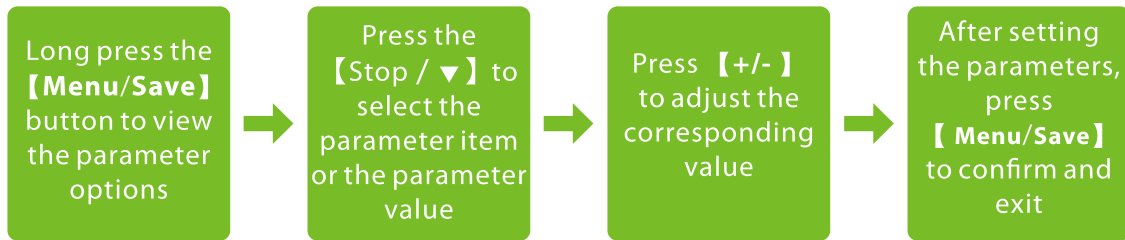

8.2 Parameter Settings Description

Items	Description	Default
01EXXX	Display Mode	01E000
	• 01E000: Displays current position of the swing arm	
	• 01E001: Controls input signal	
	• 01E002: Test mode (the digital LED displays "---" in the test mode)	
	01E102: Opening position	
	01E202: Closing position	
	01E502: Opening	
	01E602: Closing	
	01E702: In the pause	
	• 01E003: Number of boom openings	
• 01E004: Version Information		

02EXXX	<p><u>Boom Arm Opening Speed</u></p> <p>Set the Boom Arm Opening Speed to open the gate. The larger the number is set, the faster the speed. The Boom Arm Opening Speed value can be set between 10 to 32 and the default value is 24.</p>	02E024
03EXXX	<p><u>Boom Arm Opening Brake Stroke</u></p> <p>The larger the number, the longer the deceleration time and the more stable the boom arm operation. The Boom Arm Opening Brake Stroke can be set between 0 to 100 and the default value is 30.</p>	03E030
04EXXX	<p><u>Boom Arm Opening Brake Speed</u></p> <p>The smaller the number, the more pronounced the deceleration effect. The Boom Arm Opening Brake Speed can be set between 5 to 100 and the default value is 10.</p>	04E010
05EXXX	<p><u>Boom Arm Closing Speed</u></p> <p>Set the Boom Arm Closing Speed to close the gate. The larger the number is set, the faster the speed. The Boom Arm Closing Speed value can be set between 10 to 32 and the default value is 20.</p>	05E020
06EXXX	<p><u>Boom Arm Closing Brake Stroke</u></p> <p>The larger the number, the longer the deceleration time and the more stable the boom arm operation. The Boom Arm Closing Brake Stroke can be set between 0 to 100 and the default value is 40.</p>	06E040
07EXXX	<p><u>Boom Arm Closing Brake Speed</u></p> <p>The smaller the number, the more pronounced the deceleration effect. The Boom Arm Closing Brake Speed can be set between 5 to 100 and the default value is 10.</p>	07E010
08EXXX	<p><u>Sensitivity of the Boom Arm Bouncing</u></p> <p>Sets the bounce sensitivity of the boom arm when it encounters an obstacle. The higher the value, the lower the sensitivity, the longer it will take to bounce. When set to 100, this function will be turned off and the boom arm will not bounce when it encounters an obstacle. It can be set between 20 and 100, the default value is 40.</p>	08E040

09EXXX	<p><u>Close Limit Adjustment</u></p> <p>It can be set between 0 to 60, the default value is 4.</p>	09E004
10EXXX	<p><u>Open Limit Adjustment</u></p> <p>It can be set between 0 to 60, the default value is 15.</p>	10E015
11EXXX	<p><u>Automatic Closing Time for Unmanned Passage</u></p> <p>Set the time to automatically close the boom arm after successful verification but no one passes, the larger the number, the longer it takes to close the boom arm. If the "Boom Arm Opening Memory" function is turned on, the gate will not be closed even after the unmanned time when the button "Open" is pressed. The Boom Arm Opening Memory function takes priority. It can be set between 5s and 60s, the default value is 0. When set to "0", this function is turned off.</p>	11E000
12EXXX	<p><u>Boom Arm Opening Memory</u></p> <ul style="list-style-type: none"> ● 12E000: Close ● 12E001: Open <p>When more than two legal access signals are given at the same time (including the same direction and the opposite direction), the system will remember all pass requests and complete each pass in turn.</p>	12E000
13EXXX	<p><u>Core Component Position</u></p> <ul style="list-style-type: none"> ● 13E000: Right ● 13E001: Left 	13E001
14EXXX	<p><u>Reset</u></p> <ul style="list-style-type: none"> ● 14E000: -Normal ● 14E001: Reset <p>Select [14E001] will restore the default factory setting.</p> <p>(Note: The function does not clear Core Component Position and Core Component Polarity.)</p>	14E000

15EXXX	<p><u>Remote Control Pairing</u></p> <ul style="list-style-type: none"> ● 15E000: Normal ● 15E100: Add ● 15E200: Clear <p>Note: The fourth digit is adjusted by pressing [+/-] to add or clear wireless remotes, and the sixth digit shows the number of remotes that have been paired with the current device.</p>	15E000
16EXXX	<p><u>RS485 Address</u></p>	16E000
17EXXX	<p><u>Ground Sense Delay Time Setting</u></p> <p>Set the ground sense delay time by press [+/-] button, the larger the number set, the longer the delay time, the valid value is 0 to 251.</p>	17E000
18EXXX	<p><u>Core Component Type</u></p> <ul style="list-style-type: none"> ● 18E000: 20A to 0.6S ● 18E001: 18B to 1.2S ● 18E002: 18B to 2.5S <p>Please set the parameters according to the core component.</p>	18E002
19EXXX	<p><u>Boom Arm Type</u></p> <ul style="list-style-type: none"> ● 19E000: 1 to 3m ● 19E001: 3.5 to 4.5m ● 19E002: 5 to 6m <p>Please set the parameters according to the boom arm length.</p>	19E002
20EXXX	<p><u>Core Component Polarity</u></p> <ul style="list-style-type: none"> ● 20E000: Forward ● 20E001: Reverse 	20E000

21EXXX	<p><u>Power-off Open Mode</u></p> <ul style="list-style-type: none"> ● 21E000: Disable ● 21E001: Enable 	21E001
22EXXX	<p><u>Open/Close Limit LED State</u></p> <ul style="list-style-type: none"> ● 22E000: Open limit green light breathing, Close limit red light breathing ● 22E001: Open limit green light always on, Close limit red light always on ● 22E002: Open limit green light flashes, Close limit red light breathing 	22E000
23EXXX	<p><u>Open/Close LED State</u></p> <ul style="list-style-type: none"> ● 23E000: The red light flashes during the whole process of opening and closing the boom arm. ● 23E001: The red light is always on during the whole process of opening and closing the boom arm. 	23E000
24EXXX	<p><u>Remote Control Type</u></p> <ul style="list-style-type: none"> ● 24E000: 433MHz frequency ● 24E001: 430MHz frequency 	24E000

8.3 Error Code

Error Code	Description
EL0002	Power-on Self-test failure, Hall limit detection error.
EL0004	Run Timeout.
EL0008	Clutch Locked.
EL016	The code disk detection failed.
EL032	Electric Motor Shaft Lock Protection failure.

8.4 Remote Control Pairing and Unpairing

8.4.1 Pairing

Long press [**Menu/save**], then press [**Stop/▼**] flip down to [**15EXXX**]. Press [**+/-**] to set the parameter value. At this time, the LED display value is "**15EX0X**", and then press any button on the remote control until you hear a beep sound from the Mainboard, it means the pairing is successful, and then press [**Menu/save**] exit the menu.

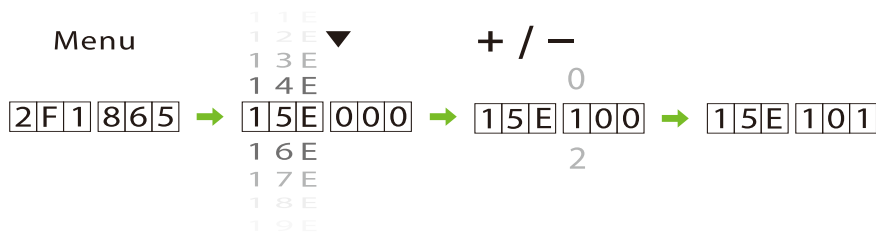

8.4.2 Unpairing

Long press [**Menu/save**], then press [**Stop/▼**] flip down to [**15EXXX**]. Press [**+/-**] to set the parameter value, and then set the parameter value to "**15E200**". Press [**Menu/save**] to save the setting and that all the remote controls have been deleted.

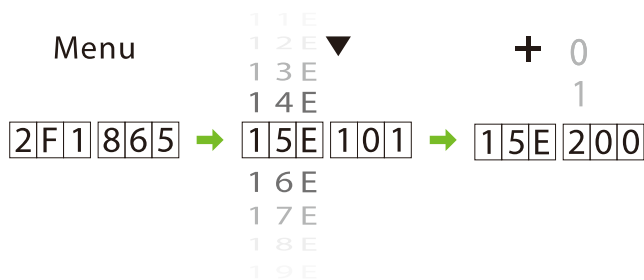

8.5 Set Delay for Automatic Closing after Opening the

Boom Arm

Long press the [**Menu/save**] button, then press [**Stop/▼**] flip down to [**11EXXX**] parameter, and then press the [**+/-**] to set the parameter value after selection. Set the delay value as per the requirements. Finally, press [**Menu/save**] to exit the menu. For example, if it is set to "**11E007**", the device will automatically close after 7 seconds after opening the barrier gate.

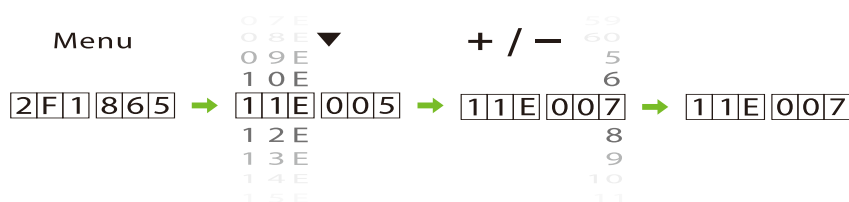

9 Boom Arm Adjustments

9.1 Dimensions

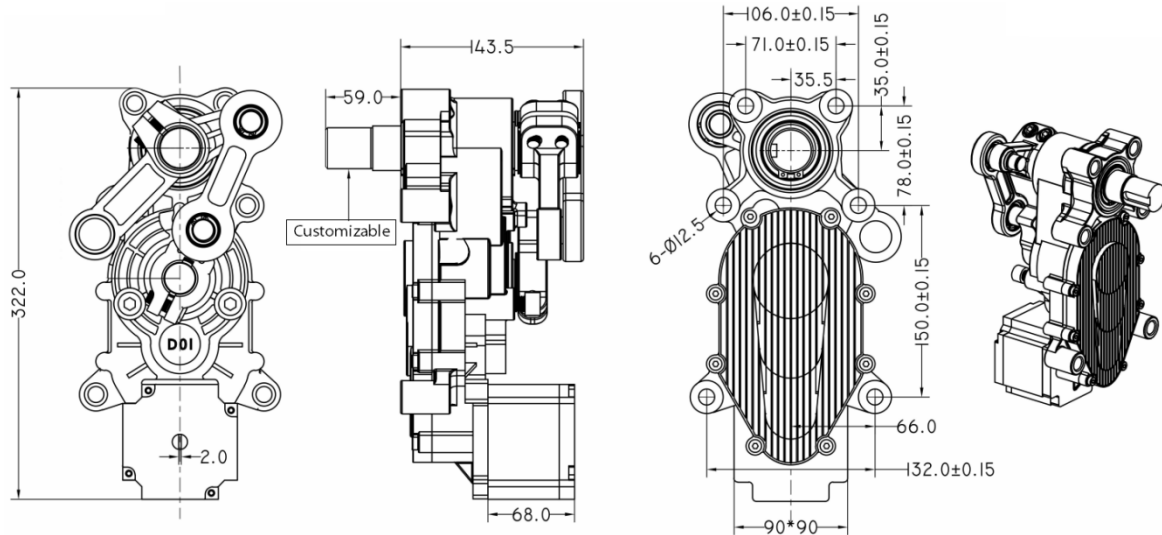

9.2 Horizontal and Vertical Angle Adjustment of Boom Arm

(Mechanical Adjustment)

Note: The horizontal and vertical angles of the boom arm have been adjusted before leaving the factory. Please do not adjust them without the guidance of professionals to avoid mechanical damage.

1. Adjust the horizontal position of the boom arm

The connecting boom crank will be an overlapping structure, with the connecting boom arm's two rotation points coincident with the reducer's output shaft at three points and a line. The boom arm is in this position horizontally. If the boom arm is not level or inclined at this time, unscrew the two rocker (rocker-arm) screws, turn the boom arm to the level, and tighten the screws.

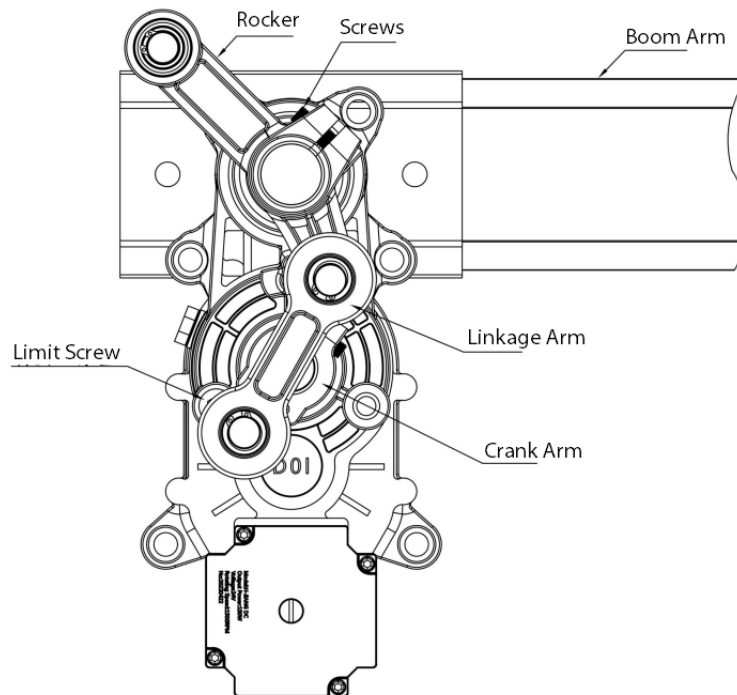

2. Adjust the vertical position of the boom arm (adjusted by mechanical structure)

The connecting boom arm crank is in an unfolded shape, and the connecting boom arm's two rotation points and the reducer's output shaft are in an unfolded 3-point line. This is the boom arm's vertical position. If the boom arm is not in the vertical position and is inclined, unscrew the two screws on the rocker (rocker-arm), rotate the boom arm to the vertical, and tighten the screws.

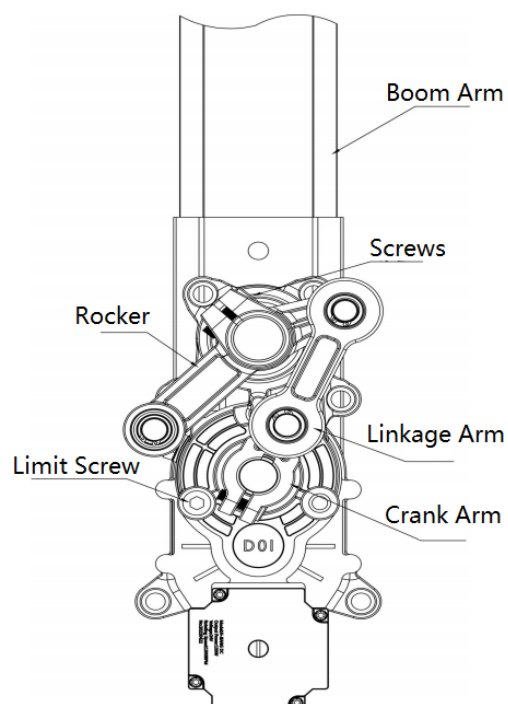

9.3 Direction Interchange of the Boom Arm

The operation steps are as follows:

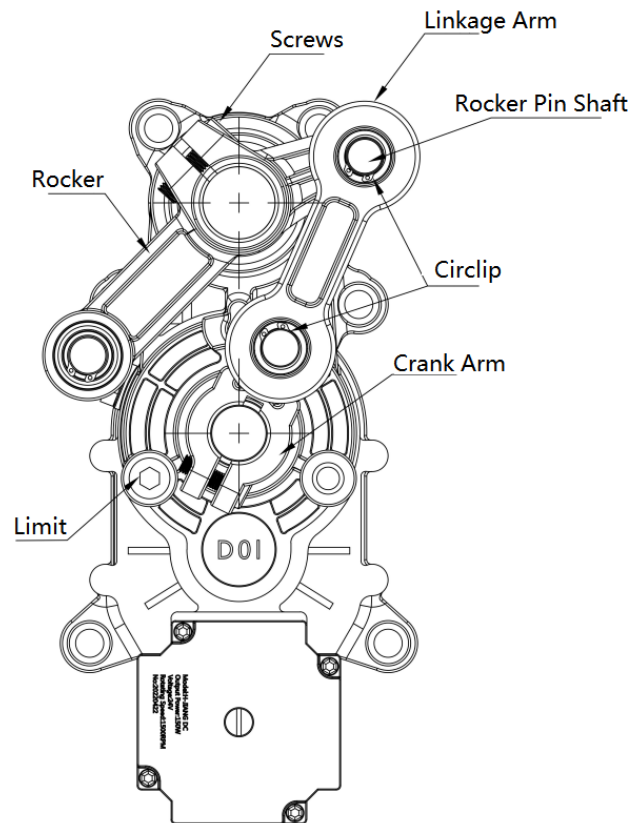

1. Before operation, please turn off the power. Remove the snap rings at both ends of the linkage arm with the external snap ring pliers and take out the linkage arm.
2. Loosen the two screws on the rocker, take out the rocker (the notch can be expanded with the help of the inclined iron to take out faster), take out the rocker pin shaft and change the direction.
3. Remove one screw on the limit, move it to the symmetrical position on the other side, and then lock it.
4. After installing the rocker pin shaft rocker of the rocker, install the linkage arm and snap rings.
5. After adjusting the angle of the boom arm, lock the rocker screw.

Note: If it is difficult to remove the linkage arm, loosen the rocker and crank arm screw and remove them together, and then remove the linkage arm.

6. After the mechanical operation, you need to set the movement parameter 13E Core Component Position on the motherboard, such as changing from L to R, the value of this parameter should be set from 1 to 0, or set the direction of the movement on the app.

9.4 Spring Adjustment

If the boom arm shakes when it rises, then you can adjust the spring loosely, and if the boom arm shakes when it falls, you can adjust the spring tightly.

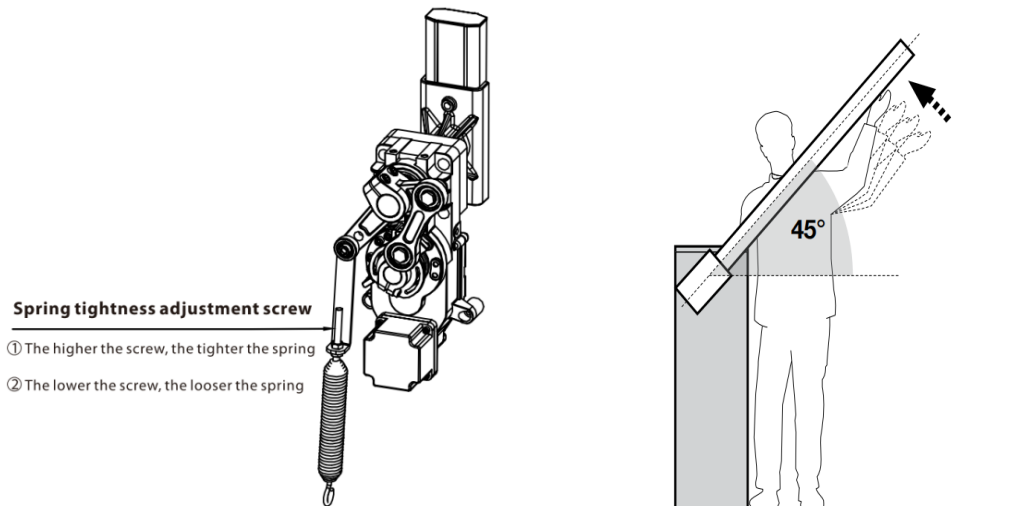

1. The best balance is when the barrier boom is at 45°.
2. The spring wire diameter is adapted to different boom lengths: 3m boom with $\phi 4.5\text{mm}$; 4.5m boom with $\phi 5.5\text{mm}$ and 6m boom with $\phi 6.5\text{mm}$. (If the boom is too short (less than 2m), do not install the spring).

10 Product Packing List

Material	Quantity
User manual	1
Chassis Explosion Screw M12X140	4
Key	2
Boom pressure plate	1
Chassis pressure plate	2
Wireless remote	2
Barrier boom hexagon bolt M10X70	2
Barrier boom	1
Machine	1

11 Troubleshooting

SN	Trouble Description	Cause	Solution
1	The Power Supply has a 24V output, but the mainboard power indicator does not light up.	<ol style="list-style-type: none"> 1. 24V output wiring might be reversed 2. The mainboard might work abnormally 3. Loose wiring 	<ol style="list-style-type: none"> 1. Swap the DC output wiring 2. Replace the Mainboard 3. Tighten the wiring
2	The AC input is normal, but the power indicator is off.	<ol style="list-style-type: none"> 1. The power fuse might be blown 2. Abnormal power supply 3. Loose wiring 	<ol style="list-style-type: none"> 1. Replace the fuse 2. Replace the power supply 3. Tighten the wiring
3	The power indicator is on, the landing boom indicator is normal, and the motor is not running.	<ol style="list-style-type: none"> 1. The motor wiring might be wrongly connected, or the wiring is loose 2. The internal encoder of the motor may work abnormally 3. The motor stroke limit exceeds the position 	<ol style="list-style-type: none"> 1. Check the wiring according to the wiring diagram, and tighten the wiring if required 2. Reconnect the motor wire 3. Re-adjust the motor limit parameters
4	The remote-control buttons do not respond.	<ol style="list-style-type: none"> 1. The remote control is not using ZKTeco brand, or it is from another model 2. The remote control does not match 3. The remote control or the receiver is damaged 4. The remote-control battery is completely discharged 	<ol style="list-style-type: none"> 1. Confirm to use ZKTeco brand and its applicable models for remote control 2. Rematch remote control 3. Replace the remote control or the receiver 4. Replace the remote-control battery
5	The boom cannot be closed normally after the machine is being powered on	<ol style="list-style-type: none"> 1. The barrier gate is not installing the barrier boom, so the motor cannot be closed due to the strong pull of the spring 2. The length of the installed boom is too short, and the spring is too tight 	<ol style="list-style-type: none"> 1. Install the boom normally or remove all the spring 2. Adjust the spring according to the length of the boom
6	The loop detector signal is not working	<ol style="list-style-type: none"> 1. Wrong signal wiring 2. Install loop coil with few or too many turns 3. Detector damage 	<ol style="list-style-type: none"> 1. Connect according to the wiring diagram 2. Calculate the circumference of the loop coil according to the width of the lane, and then confirm the number of turns install 3. Replace new loop detector

7	The radar detector signal is not working	<ol style="list-style-type: none"> 1. Wrong signal wiring 2. Distance and environment learning is not correct 3. Detector damage 	<ol style="list-style-type: none"> 1. Connect according to the wiring diagram 2. Complete the installation test through the radar installation video or the user manual 3. Replace new radar detector
8	Abnormal shaking of the barrier boom occurred while opening and closing	Spring too tight or too loose and the running speed too fast	If the boom arm open shaking, it is necessary to loosen the spring and slow down the speed appropriately; If the boom arm close shaking, it is necessary to tighten the spring and slow down the speed appropriately.
9	The boom is not vertical and parallel after opening or closing	<ol style="list-style-type: none"> 1. The spindle is not properly calibrated 2. Encoder travel limit error 	<ol style="list-style-type: none"> 1. Loosen the screw on the spindle connecting arm and then adjust and calibrate the spindle direction 2. Adjust travel limit parameters again
10	Abnormal sound is heard when the motor is running	<ol style="list-style-type: none"> 1. Motor rotor bearing is being damaged 2. Operating handle broken 	<ol style="list-style-type: none"> 1. Replace new motor 2. Replace the new operating handle

ZKTeco Industrial Park, No. 32, Industrial Road,

Tangxia Town, Dongguan, China.

Phone : +86 769 - 82109991

Fax : +86 755 - 89602394

www.zkteco.com



Copyright © 2023 ZKTECO CO., LTD. All Rights Reserved.